

MetalSCAN

On-Line Oil Debris Monitor

MS3201 SENSOR

Unequaled protection for aerospace, marine and energy equipment applications. Thousands of MetalSCAN units already installed protecting high-value, mission-critical and process-critical rotating equipment.

MetalSCAN MS3000 is a low cost, high reliability, advanced on-line condition monitor designed to detect the presence of both ferrous and non-ferrous metal particles that are generated from bearing or gear damage.

- Proven to provide the earliest reliable detection of component damage.
- Monitor damage progression and estimate remaining life.
- Avoid equipment secondary damage.
- Avoid unplanned outages.

APPLICATION

MS3000 is designed to be easily installed in the full flow of the lubrication system before the oil filter to detect the presence of metal particles.

The sensor generates an electrical pulse for each metal particle above its minimum size threshold. The signal is designed to interface to a host, either a MS3000 Display Unit or directly to a monitoring or control system. The host recognizes the passage of the particle, and increments a counter which is then compared to machinery condition indicators. The condition indicators are based upon simple criteria which establish whether the machine is healthy or not, and if not how much damage there is, and how much longer the machine can be operated. All performed local to the host with no need for expensive expert based analysis and consultations.



FEATURES:

- On-line, real-time condition monitoring
- Full flow design
- 100% Detection of Fe and NFe metal particles
- Easy to install
- No special skills required to interpret data
- Rugged design
- Solid-state, no moving parts
- Full function continuous built-in test
- Proven reliability in harsh machinery environments



MS3201 SENSOR

Sensor Bore	Minimum Detectable Spherical Particle		Minimum Flow Rate	Maximum Particle Detection Rate
	Fe	NFe		
8 mm	125 µm	450 µm	0.5 l/min	65 particles/sec

Particle Pulse:

Shape	square wave pulse	square wave pulse
Width	5 ± 2 ms	5 ± 2 ms
Pulse + Dead Time.....	15 ± 3 ms	15 ± 3 ms
Amplitude	Power Supply +0/-2 VDC	5 VDC differential
Max. Output Current	15 mA (1kΩ load impedance)	10 mA (48Ω load impedance)

Built-in Test:

Shape	HI or LO logic	HI or LO logic
Fault State	0.0 VDC	0.0 VDC
No Fault State	Power Supply +0/-2 VDC	5 VDC differential
Max. Output Current.....	15 mA (1kΩ load impedance)	10 mA (48Ω load impedance)

Power Supply.....18 to 30 VDC @ 3.6W (max)
(120 mA @ 24 VDC)

Oil Pressure	Maximum 20 bar (300 psi)
Oil Temperature.....	-40°C to 85°C
Ambient Temperature.....	-40°C to 70°C
Vibration.....	15 mm/s @ 0 to 300 Hz
Fluids Compatibility.....	Hydraulic & lubrication oils; synthetic & mineral based; solvents & cleaning agents.

Compliance:

- CE (EN61326, EN61010, 97/23/EC)
- ASME B31.3B (Process Piping Standard)
- IP66

Accessories:

1. MS3000 Alarm Module (order: Alarm-3001).
2. Application adapter kits (contact GasTOPS with specific requirements).
3. Cable kits (contact GasTOPS with specific requirements).
4. Particle Test Tool for confirming operation (order: Tool-3001).

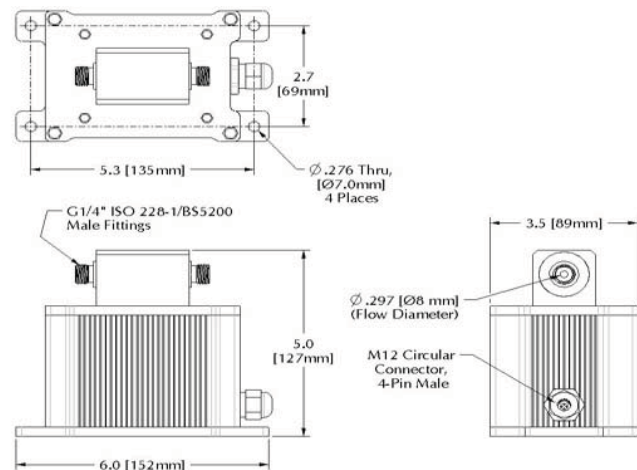

Model	Bore	Length	Height	Width	Weight	Fluid Fitting
Sensor - 3201	8 mm (0.3in)	152mm (6.0in)	127mm (5.0in)	89mm (3.5in)	1.6kg (3.5lb)	-G1/4" ISO 228-1/ BS5200 Male Fittings



Sole Distributor in the UK and Ireland:

windpower renewable solutions Ltd
G3 West Mill, Imperial Business Estate
Gravesend, Kent DA11 0DL
Tel. +44 1474 534251 ● Fax +44 1474 534566
www.windpower-renewable-solutions.com ● info@windpower-renewable-solutions.com